

FG

**Gas Filters
DN15 ... DN150**

FG

Gas Filters

Contents

Description	2
Features	2
Functioning and application	3
Accessories and optionals	4
Technical specifications	4
Gas flow chart (pressure drop)	6
Ordering information	8
Standards and approvals	9

Description

The FG type is a filter for gas pipelines according to DIN 3386, with very high holding capacity of dust and impurities, suitable for the protections of devices installed downstream.

Features

The filters are made of aluminum alloy die-cast, with a wide range for inlet/outlet connections from DN15 up to DN 150.

Suitable for natural gas, town gas, LPG (gaseous), biologically produced methane and air. On request the filters can be provided with special seals suitable for aggressive gases (COG).

The incorporated filtering cartridge is a steel support frame covered with an high performance nonwoven made of polyolefine fibers, which satisfy the stringent requirements of Fire Class F1 according to DIN 53438 and are thus self-extinguishing.

Considering the same connection, the FGS are smaller models of FG filters: the body is more compact with a reduced filtering surface.

FGS1-FGS2 models are provided with a mesh filter cartridge.

Provided with pressure gauges for both inlet and outlet chamber (optional for threaded models).

All components are designed to withstand any mechanical, chemical and thermal condition occurring during typical service. Effective impregnation and surface treatments have been used to improve mechanical sturdiness, sealing and resistance to corrosion of the components.

Filters are 100% tested by computerized testing machineries and are fully warranted.



WARNING

This appliance must be installed in compliance with the rules in force.

Functioning and application

The FG type filter is designed for installation in gas lines and compressed air lines, to protect downstream fittings.

The filtering cartridge made of nonwoven polypropylene fibers with a metal support frame, is suitable to retain dust and other impurities with size $\geq 50\mu\text{m}$.

When the dust storage capacity is exceeded or if there is an excessive pressure difference, the filter loses its protective function. In this case the filter element must be replaced.

FGS1-FGS2 models are provided with a mesh filter cartridge, which is easy washable.

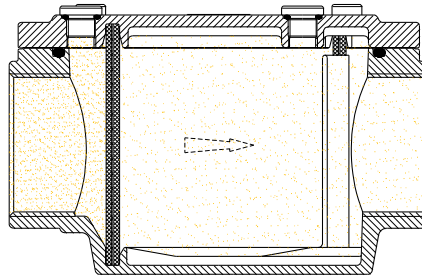

Fig.1

Figure 2 shows an example of installation.

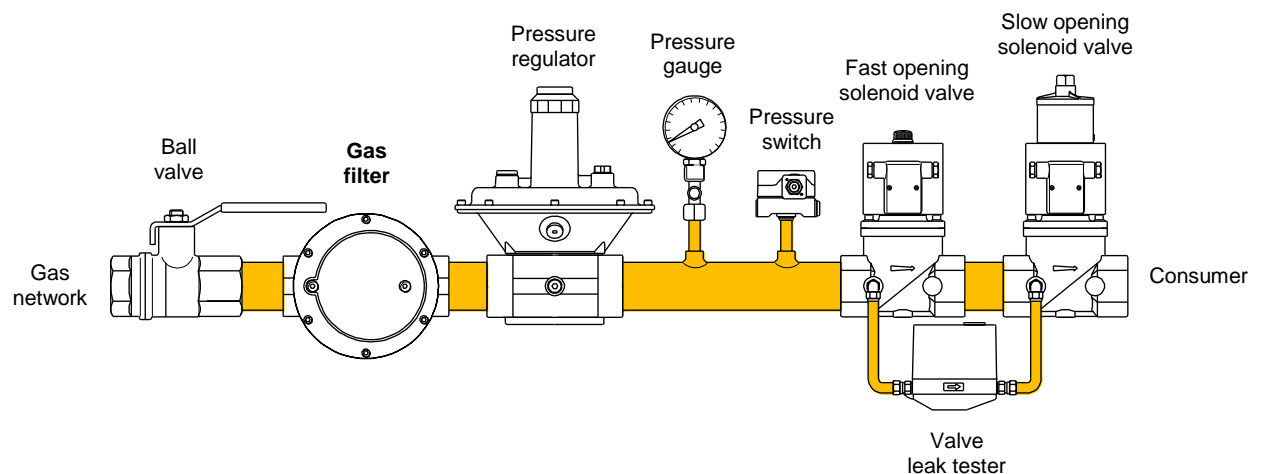

Fig.2



WARNING

Location and mode of installation must be in compliance with local rules in force.

Accessories and optionals

Inlet and outlet pressure chambers can be provided with pressure gauges, to connect a gas differential pressure switch to monitor the pressure difference.

On request a test point fitting can be provided (mounting in charge of the user).

Technical specifications

Tab. 1

Connections	Gas threaded ISO 7-1 from Rp1/2 to Rp2 Flanged PN16 – ISO 7005 from DN65 to DN150
Max. operating pressure	2 bar (200 kPa) 6 bar (600 kPa)
Ambient temperature	-15°C / +80°C
Flow capacity	see charts
Pore width of filter element	≤ 50 µm
Filtration class	G4 according to EN 779
Pressure gauges (when provided)	Inlet and outlet chambers G1/8 onto threaded models (except FGS1-FGS2) G1/4 onto flanged models according to ISO 228-1
Installation	Into horizontal and vertical pipeline
Gas type	Natural gas, town gas, LPG (gaseous) of families 1,2,3 biologically produced methane and air On request special version for COG
Materials in contact with gas	Aluminium alloy Plated steel Polypropylene fibers Nitrile rubber (NBR) Fluoroelastomer (FPM) (optional)

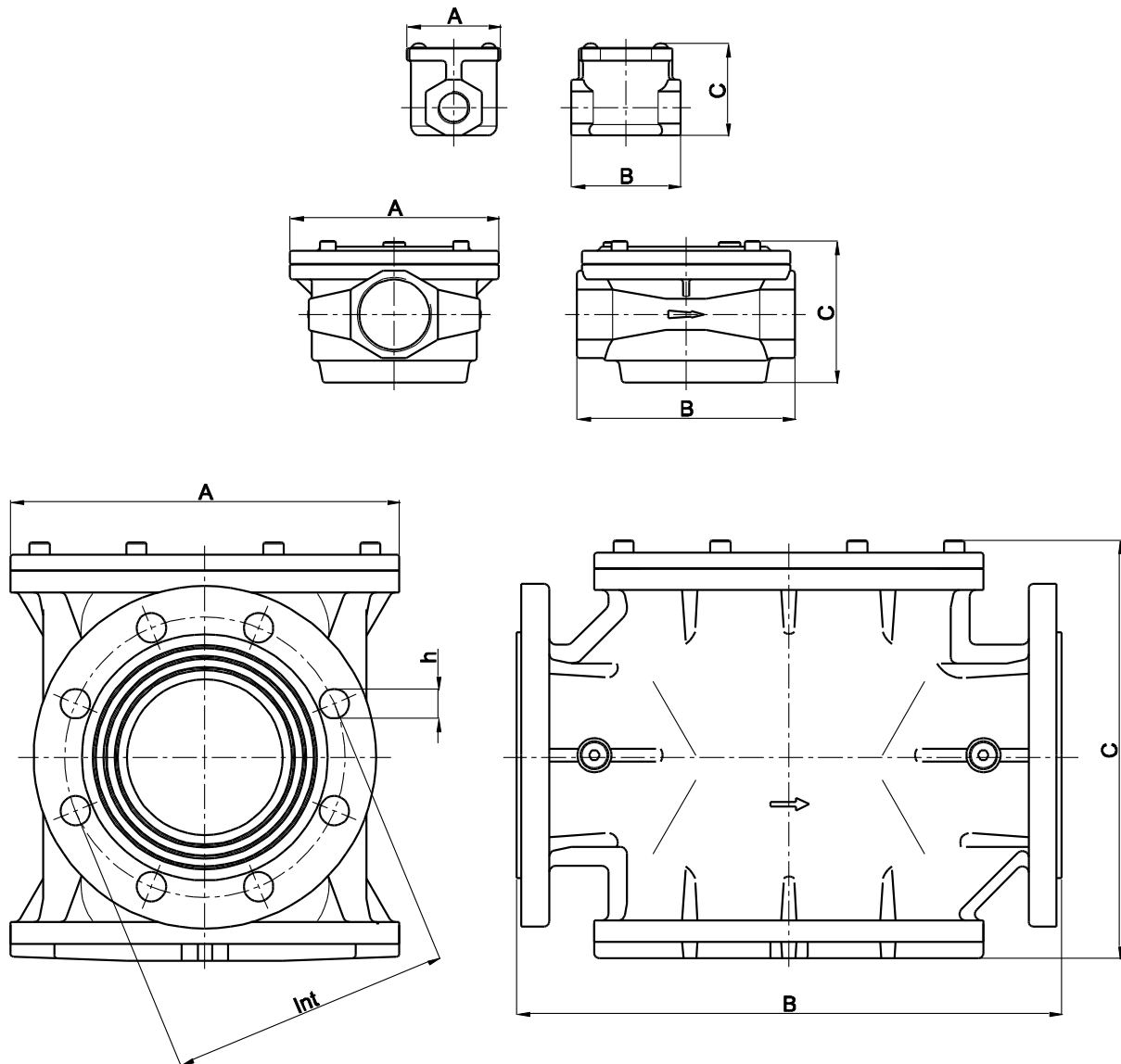

Fig.3

Tab. 2

Model	Connection	Flow factor Kvs [m ³ /h]	Overall dimensions [mm]					Weight [Kg]	Filtering area [cm ²]
			A	B	C	Int	h		
FGS1	Rp 1/2	6,8	60	70	60			0,24	17
FGS2	Rp 3/4	11	60	70	60			0,22	17
FG1	Rp 1/2	6,8	88	96	84			0,39	55
FG2	Rp 3/4	11	88	96	84			0,38	55
FGS3	Rp 1	14	88	96	84			0,36	55
FG3	Rp 1	19	134	140	91			0,97	145
FG35	Rp 1 1/4	24	134	140	91			0,91	145
FGS4	Rp 1 1/2	28	134	140	91			0,85	145
FG4	Rp 1 1/2	40	182	208	128			2,2	330
FG6	Rp 2	56	182	208	128			2,0	330
FG7	DN 65	110	200	308	212	145	4x18	8,5	535
FG8	DN 80	150	200	308	212	160	8x18	8,4	535
FG9	DN 100	220	250	350	265	180	8x18	13,5	860
FG93	DN 125	350	315	460	347	210	8x18	22,8	1540
FG95	DN 150	450	315	460	347	240	8x23	24,5	1540

Gas flow chart

(Pressure drop)

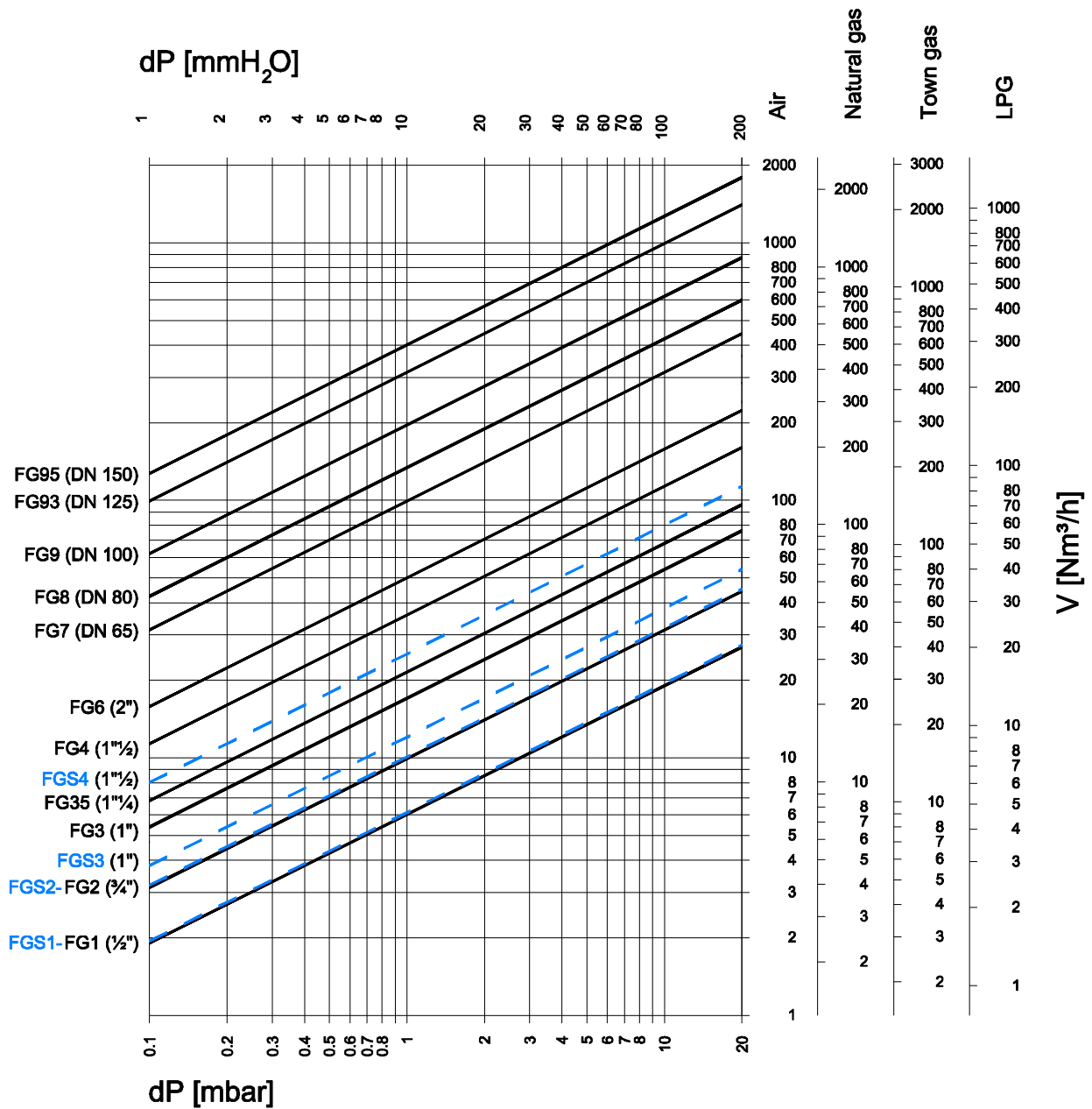

Fig. 4

Formula of conversion from air to other gases

$$V_{GAS} = k \cdot V_{AIR}$$

Tab. 3

Gas type	Specific gravity ρ [Kg/m ³]	$k = \sqrt{\frac{1,25}{\rho_{GAS}}}$
Air	1,25	1,00
Natural gas	0,80	1,25
Town gas	0,57	1,48
LPG	2,08	0,77

15°C, 1013 mbar, dry

When the flow read on the diagram is referred to operating pressure instead of standard conditions, the pressure drop Δp read on the diagram must be multiplied for the factor (1+ relative pressure in bar):

Example:

In the 2" filter with an air flow of 100 Nm³/h there is a pressure drop $\Delta p = 4$ mbar. If we consider that 100 m³/h is the flow at 2 bar of inlet pressure, then the pressure drop to be consider is:

$$\Delta p = 4 \times (1 + 2) = 12 \text{ mbar}$$



Filter must be selected considering the following:

- Pressure drops $\Delta p \leq 10$ mbar
- Flow velocities $w \leq 20$ m/s

Normally, pressure drop and flow rate for the filters are read from the gas flow diagram. However, the filters can also be chosen in accordance with the characteristic "Kvs value" which is shown in table 2.

The selection of the filter requires the calculation of the Kv under the operating conditions.

Considering only subcritical pressure drops:

$$\Delta p < \frac{p_1}{2}$$

Kv can be calculated with the formula:

$$Kv = \frac{V}{514} \sqrt{\frac{\rho(t + 273)}{\Delta p \cdot p_2}}$$

where

- V = flow rate [Nm³/h]
- Kv = flow factor [m³/h]
- ρ = density [Kg/m³]
- p_1 = absolute inlet pressure [bar]
- p_2 = absolute outlet pressure [bar]
- Δp = differential pressure $p_1 - p_2$ [bar]
- t = media temperature [°C]

To the Kv value calculated from operating conditions we add an allowance of 20%, to obtain the minimum Kvs value which the filter should have:

Kvs > 1,2 Kv

Example:

We need a filter with a capacity of 100 Nm³/h of air at 15°C, with an inlet pressure $p_1 = 2$ bar. Considering a pressure drop $\Delta p_{max} = 10$ mbar, we obtain:

$$Kv = \frac{100}{514} \sqrt{\frac{1.25(15 + 273)}{0.010 \cdot (1 + 2)}} = 21.3 \text{ m}^3 / \text{h}$$

The filter with Kvs > (1,2 x 21,3) = 25,5 m³/h is the DN40, which has Kvs=40 m³/h (table 2). The diagram shows that in a DN40 filter with 100 Nm³/h of air there is a pressure drop:

$$\Delta p = 7,8 \text{ mbar}$$

Ordering information

Tab.4

Connections		2 bar	6 bar	Additional code
Threaded	Rp 1/2	FGS12	FGS16	none= without pressure gauges (no drilled) A= screw plug 1/8" at the inlet and outlet (except FGS1-FGS2) K= special seals for aggressive gases
		FG12	FG16	
	Rp 3/4	FGS22	FGS26	
		FG22	FG26	
	Rp 1	FGS32	FGS36	
		FG32	FG36	
	Rp 1 1/4	FG352	FG356	
Rp 1 1/2	FGS42	FGS46		
	FG42	FG46		
Rp 2	FG62	FG66		
Flanged	DN 65	FG72	FG76	A= screw plug 1/4" at the inlet and outlet K= special seals for aggressive gases
	DN 80	FG82	FG86	
	DN 100	FG92	FG96	
	DN 125	FG932	FG936	
	DN 150	FG952	FG956	



Example:

FGS42.A for a filter with Rp11/2 threaded connections, Pmax= 2 bar, small size and screw plug at the inlet and outlet.

Test point fittings must be order with their ordering code.



Manufacturer reserves the right to update or make technical changes without prior notice.

Standards and approvals

The filters design meets current European approval requirements regarding filtering functions on gaseous fuels.

These products conform with the Pressure Equipment Directive (97/23/EC) and the certification has been issued by the notified body:

C.S.I. Spa
Viale Lombardia 20
I-20021 Bollate (MI)



Quality Management System is certified according to UNI EN ISO 9001 and the monitoring is carried out by the notified body:

Kiwa Gastec Italia Spa
Via Treviso, 32/34
I- 31020 San Vendemiano (TV)

